

超硬ホルダー最終進化

max point®

タングステンヘッドがボーリング加工を変える

タングステンヘッド

特許出願中

まさしくソリッドの
使い心地!



より強く、より深く、より長く!

SONEDA

最終進化

maxVpoint

タングステンヘッドがボーリング加工を変える

タングステン合金採用。
高精度と強度、耐ビビリ性能を実現、
完全ソリッドホルダーに迫る性能。

耐ビビリ性能の高い高密度、高ヤング率
超硬合金を採用。

超硬を極限までチップに近付ける事により
高精度加工が実現。従来メーカーよりもさ
らに突き出しアップが可能!

接合部面積を従来の1.5倍にする事により、高強度な
接合を実現し、焼結タングステン同士の接合で歪み
が無く隙間の発生もありません。



高精度加工の実現!

タングステン合金ヘッドを採用超硬ソリッド同等の高精度を実現。



ホルダー寿命大幅アップ!

タングステン合金ヘッドが従来スチールヘッドの5倍~10倍の耐摩耗性能アップ。



高信頼性能1

焼結合金同士の結合により接合時の歪みが無く密着強度がアップ。



高信頼性能2

接合部の断面積を従来メーカーの1.5倍にする事により強度アップを実現。



高精度、極限加工

超硬部をチップに極限まで近づけるV point形状により、高精度加工と更なる突き出しを可能にし、
切り屑排出性能も良好。

高精度 加工UP



チップ座面までヤング率の高い材料
を使用、特殊な接合方法と形状でた
わみがありません。

ホルダー 寿命UP

従来品: 3ヵ月使用
使用不可
寸法ばらつき発生



maxVpoint: 6ヵ月使用
変化無し
問題無く使用継続中



従来品とmaxVpointの比較です。
従来品は3ヵ月使用で切りくずによる
摩耗がひどく使用できない状態になっ
ております。
当社maxVpointは切りくずによる摩
耗も無く、良好な状態で6ヵ月使用後
現在も使用中。

突き出し 量UP



超硬トップ部が違うから
突き出し量がさらにアップ!

THE NEXT STEP OF EVOLUTION

maxVpoint

The tungsten head changes boring process

Using the tungsten-alloy. Achieves the high precision, strength, anti-vibration, and high performance as a solid holder.

The shank uses the cemented carbide, so it offers high density and high young's modulus.



Extreme close carbide up to insert, so it makes high precision processing. therefore overhang is up than currently manufactures.

The Joint cross sectional area is 1.5 times wider, and also fellow the sintering tungsten are bonded, so no distortion gaps.



The Best High Precision Cutting Tool

With the innovation of the tungsten-alloy head. maxVpoint is setting a new standard for high performance of solid holders.



The Holder Is Made to Last!

The tungsten-alloy head holder life is 5 to 10 times longer than steel head holder.



High Quality Performance Guarantee -1-

There is no distortion, so degree of adhesion is up because we bonded fellow sintered alloys.



High Quality Performance Guarantee -2-

The Joint cross sectional area is 1.5 times wider, so the strength is up.



High Precision, Extreme Processing

Extreme close carbide up to insert "Vpoint" shape, so it makes high precision processing and more overhang. Also the excellent chip control, too.

Good High-Precision



We use high young's modulus to the insert seat. And also we adopt special way for united and special shape of the head, therefore no swang!

Long Lasting

Currently :
3 months used.
Unusable.
The quality of the products is uneven.



maxVpoint :
6 months used.
No change.
Still usable.



Compare between Currently holder and maxVpoint. A currently holder can't use anymore in 3 months because it is worn by chips. On the other hand, our maxVpoint; no worn by the chips, being good condition up to 6 months.

Good Overhang



The top of the carbide shanks are different, so overhangs can be up!

C-STUP(B)R/L

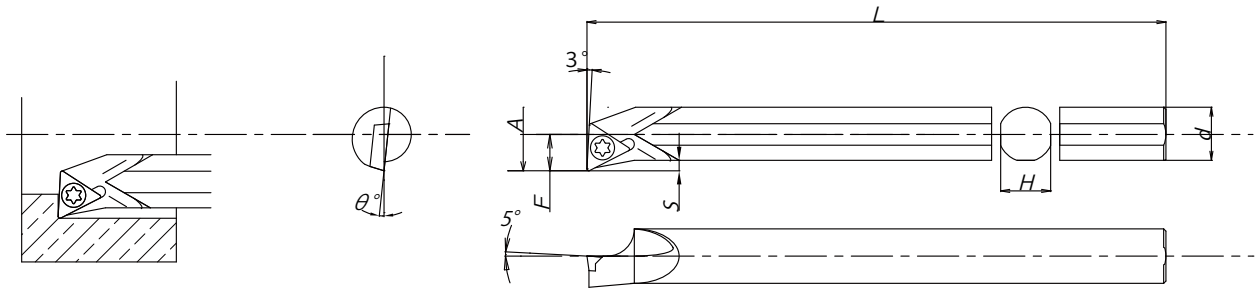

※ 本図は右勝手 (R) を示します。
Above figures shows right hand tools.

Cat. No. 型番	Stock 在庫		Min. Bore Dia. 最小 加工径	Dimensions(mm) 寸法 (mm)					θ	基準 コーナ Radius	Spare Part 部品 Screw クランプスクリュー	Applicable Insert 使用チップ
	R	L		φA	φd	H	L	F				
C10-STUB ㄨ 06-08V-140	●	●	8	10	9	140	4	0.5	12°	0.2	S-1STR	TB**0601**
C08-STUP ㄨ 08-10V-170	●	●	10	8	7.2	170	5		10°			
STUP ㄨ 08-10V-100	●	△				12		10	9	100	6	8°
C10-STUP ㄨ 09-12V-175	●	●	12	10	9		175			7		
STUP ㄨ 09-12V-80	●	△				14	12	11	80		0.7	7°
STUP ㄨ 09-12V-105	●	△	14	12	11				105	0.7		
C12-STUP ㄨ 09-14V-175	●	●				14	12	11	175		7	7°
STUP ㄨ 09-14V-90	●	△	16	14	13				90	0.3		
STUP ㄨ 09-14V-120	●	△				16	14	13	120		0.3	5°
C10-STUP ㄨ 11-12V-175	●	●	12	10	9				175	8		
STUP ㄨ 11-12V-80	●	△				16	14	13	80		0.3	5°
STUP ㄨ 11-12V-105	●	●	16	14	13				105	0.3		
C12-STUP ㄨ 11-14V-175	●	●				14	12	11	175		8	0.3
STUP ㄨ 11-14V-90	●	△	16	14	13				90	0.3		
STUP ㄨ 11-14V-120	●	●				16	14	13	120		0.3	5°
C12-STUP ㄨ 11-16V-175	●	●	16	14	13				175	8		
STUP ㄨ 11-16V-90	●	△				18	16	15	90		0.3	4°
STUP ㄨ 11-16V-120	●	●	18	16	15				120	0.3		
C14-STUP ㄨ 11-16V-175	●	●				16	14	13	175		8	0.3
STUP ㄨ 11-16V-90	●	△	20	18	17				90	10		
STUP ㄨ 11-16V-120	●	△				20	18	17	120		10	0.8
C16-STUP ㄨ 11-18V-210	●	●	18	16	15				210	10		
STUP ㄨ 11-18V-110	●	△				20	18	17	110		10	0.8
STUP ㄨ 11-18V-145	●	●	20	18	17				145	10		
C16-STUP ㄨ 11-20V-210	●	●				20	18	17	210		10	0.8
STUP ㄨ 11-20V-110	●	△	22	20	19				110	11		
STUP ㄨ 11-20V-145	●	●				22	20	19	145		11	0.7
C18-STUP ㄨ 11-20V-230	●	●	20	18	17				230	11		
STUP ㄨ 11-20V-120	●	△				25	25	19	120		12.5	0.3
STUP ㄨ 11-20V-175	●	△	25	25	19				175	12.5		
C20-STUP ㄨ 11-22V-245	●	●				22	20	19	245		12.5	0.3
STUP ㄨ 11-22V-125	△	△	25	25	19				125	12.5		
STUP ㄨ 11-22V-175	△	△				25	25	19	175		12.5	0.3
C20-STUP ㄨ 16-25V-245	●	●	25	25	19				245	12.5		
STUP ㄨ 16-25V-125	△	△				25	25	19	125		12.5	0.3
STUP ㄨ 16-25V-175	●	●	25	25	19				175	12.5		

※ ㄨ : 右勝手 (R) ホルダには左勝手 (L) チップ、左勝手 (L) ホルダには右勝手 (R) チップが適合します。※ 在庫欄の●は標準在庫、△は2~3営業日、空欄は受注生産となります。

E-STUP(B)R/L

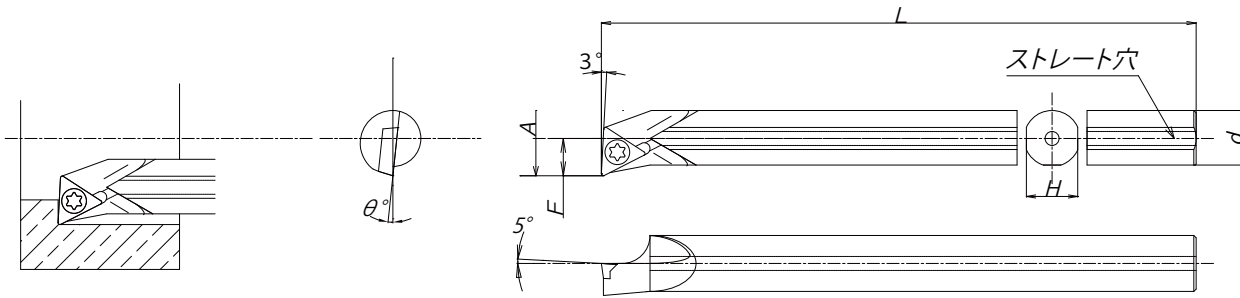

※) 本図は右勝手 (R) を示します。
Above figures shows right hand tools.

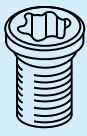
new Cat. No. 型番	Stock 在庫		Min. Bore Dia. 最小加工径	Dimensions(mm) 寸法 (mm)					θ	基準 コーナ Nose Radius R	Spare Part 部品 Screw クランプスクルー 	Applicable Insert 使用チップ
	R	L		ϕ A	ϕ d	H	L	F				
E10-STUB ㊄ 06-08V-140	●	●	8	10	9	140	4	0.5	12°	0.2	S-1STR	TB**0601**
E08-STUB ㊄ 08-10V-170	●	●	10	8	7.2	170	5		10°	0.4	S-1TR	TP**0802**
STUB ㊄ 08-10V-100	●	△				100						
E10-STUB ㊄ 09-12V-175	●	●	12	10	9	175	6	8°	0.4	S-2TR	TP**0902**	
STUB ㊄ 09-12V-80	●	△				80						
STUB ㊄ 09-12V-105	●	△				105						
E12-STUB ㊄ 09-14V-175	●	●	14	12	11	175	7	0.7	7°	0.4	S-3STR	TP**1103**
STUB ㊄ 09-14V-90	●	△				90						
STUB ㊄ 09-14V-120	●	△				120						
E10-STUB ㊄ 11-12V-175	●	●	12	10	9	175	6	0.5	8°	0.4	S-3STR	TP**1103**
STUB ㊄ 11-12V-80	●	△				80						
STUB ㊄ 11-12V-105	●	●				105						
E12-STUB ㊄ 11-14V-175	●	●	14	12	11	175	7	0.5	7°	0.4	S-3STR	TP**1103**
STUB ㊄ 11-14V-90	●	△				90						
STUB ㊄ 11-14V-120	●	●				120						
E12-STUB ㊄ 11-16V-175	●	●	16	14	13	175	8	0.3	5°	0.4	S-3TR	TP**1103**
STUB ㊄ 11-16V-90	●	△				90						
STUB ㊄ 11-16V-120	●	●				120						
E14-STUB ㊄ 11-16V-175	●	●	16	14	13	175	9	0.3	4°	0.4	S-3TR	TP**1103**
STUB ㊄ 11-16V-90	●	△				90						
STUB ㊄ 11-16V-120	●	△				120						
E16-STUB ㊄ 11-18V-210	●	●	18	16	15	210	10	0.8	3°	0.4	S-4TR	TP**1603**
STUB ㊄ 11-18V-110	●	△				110						
STUB ㊄ 11-18V-145	●	●				145						
E16-STUB ㊄ 11-20V-210	●	●	20	18	17	210	11	0.7	-2°	0.8	S-4TR	TP**1603**
STUB ㊄ 11-20V-110	●	△				110						
STUB ㊄ 11-20V-145	●	●				145						
E18-STUB ㊄ 11-20V-230	●	●	20	18	17	230	12.5	0.3	0°	0.8	S-4TR	TP**1603**
STUB ㊄ 11-20V-120	●	△				120						
STUB ㊄ 11-20V-175	●	△				175						
E20-STUB ㊄ 11-22V-245	●	●	22	20	19	245	11	0.7	-2°	0.8	S-4TR	TP**1603**
STUB ㊄ 11-22V-125	△	△				125						
STUB ㊄ 11-22V-175	△	△				175						
E20-STUB ㊄ 16-25V-245	●	●	25	20	19	245	12.5	0.3	0°	0.8	S-4TR	TP**1603**
STUB ㊄ 16-25V-125	△	△				125						
STUB ㊄ 16-25V-175	●	●				175						

※) ㊄ : Right handed toolholders are applicable with left handed or neutral inserts. Left handed toolholders are applicable with right handed or neutral inserts. We have stock with ●

C-SCLCR/L

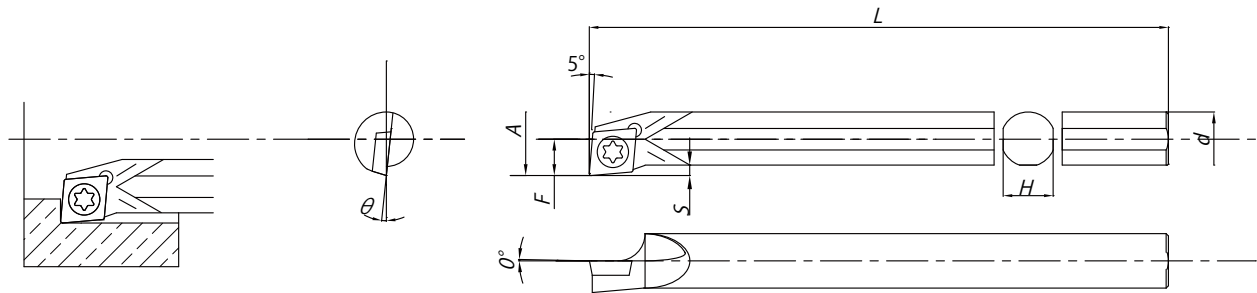

※) 本図は右勝手 (R) を示します。
Above figures shows right hand tools.

Cat. No. 型番	Stock 在庫		Min. Bore Dia. 最小 加工径	Dimensions(mm) 寸法 (mm)				θ	基準 コーナ Radius	Spare Part 部品	Applicable Insert 使用チップ
	R	L		ϕ A	ϕ d	H	L			F	
C04-SCLC ㊦ 03-05V-90	●	●	5	4	3.8	90	2.5	15°	0.2	S-1635TR	CC**0301**
C05-SCLC ㊦ 03-06V-100	●	●	6	5	4.4	100	3	13°		S-2040TR	CC**0401**
C06-SCLC ㊦ 04-07V-110	●	●	7	6	5.4	110	3.5	13°		S-2545TR	CC**0602**
C07-SCLC ㊦ 04-08V-125	●	●	8	7	6.4	125	4	11°			
C08-SCLC ㊦ 06-10V-170	●	●	10	8	7.2	170	5	10°			
SCLC ㊦ 06-10V-140	●	△				140					
C10-SCLC ㊦ 06-12V-175	●	●	12	10	9	175	6	12°	0.4	S-4065TR	CC**09T3**
C12-SCLC ㊦ 06-14V-175	●	●	14	12	11		7	10°			
C12-SCLC ㊦ 09-16V-175	●	●	16								
C16-SCLC ㊦ 09-18V-210	●	●	18	16	15	210	9	10°			
SCLC ㊦ 09-18V-145	●	●				145					
SCLC ㊦ 09-18V-175	●	●				175					
C20-SCLC ㊦ 09-22V-245	●	●	22	20	19	245	11	5°			
SCLC ㊦ 09-22V-175	●	△				175					

※) C04-SCLC 03-05V Rake angle is 2°
※) C08-SCLC 06-10V Rake angle is 3°

※) C04-SCLC 03-05V はすくい角度は 2°
※) C08-SCLC 06-10V はすくい角度は 3°

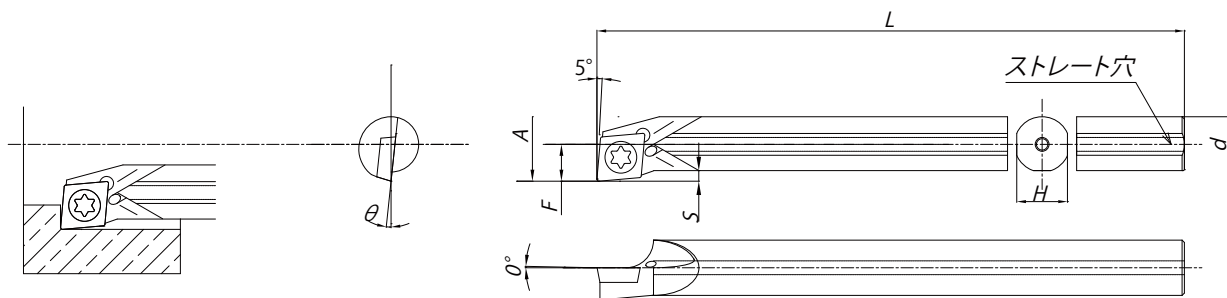

※) 本図は右勝手 (R) を示します。
Above figures shows right hand tools.

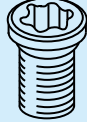
new Cat. No. 型番	Stock 在庫		Min. Bore Dia. 最小 加工径 φ A	Dimensions(mm) 寸法 (mm)				θ	基準 コーナ Radius R	Spare Part 部品	Applicable Insert 使用チップ
	R	L		φ d	H	L	F			Screw クランプスクリュー 	
E04-SCLC ㄣ 03-05V-90	●	●	5	4	3.8	90	2.5	15°	0.2	S-1635TR	CC**0301**
E05-SCLC ㄣ 03-06V-100	●	●	6	5	4.4	100	3	13°		S-2040TR	CC**0401**
E06-SCLC ㄣ 04-07V-110	●	●	7	6	5.4	110	3.5	13°		S-2545TR	CC**0602**
E07-SCLC ㄣ 04-08V-125	●	●	8	7	6.4	125	4	11°			
E08-SCLC ㄣ 06-10V-170	●	●	10	8	7.2	170	5	10°	0.4	S-4065TR	CC**09T3**
SCLC ㄣ 06-10V-140	●	△				140		10°			
E10-SCLC ㄣ 06-12V-175	●	●	12	10	9	175	6	12°			
E12-SCLC ㄣ 06-14V-175	●	●	14	12	11		7	10°			
E12-SCLC ㄣ 09-16V-175	●	●	16				8	10°			
E16-SCLC ㄣ 09-18V-210	●	●	18	16	15	210	9	10°			
SCLC ㄣ 09-18V-145	●	●				145					
SCLC ㄣ 09-18V-175	●	●				175					
E20-SCLC ㄣ 09-22V-245	●	●	22	20	19	245	11	5°			
SCLC ㄣ 09-22V-175	●	△				175					

※) E04-SCLC 03-05V Rake angle is 2°
※) E08-SCLC 06-10V Rake angle is 3°

※) E04-SCLC 03-05V はすくい角度は 2°
※) E08-SCLC 06-10V はすくい角度は 3°

C-SCLPR/L

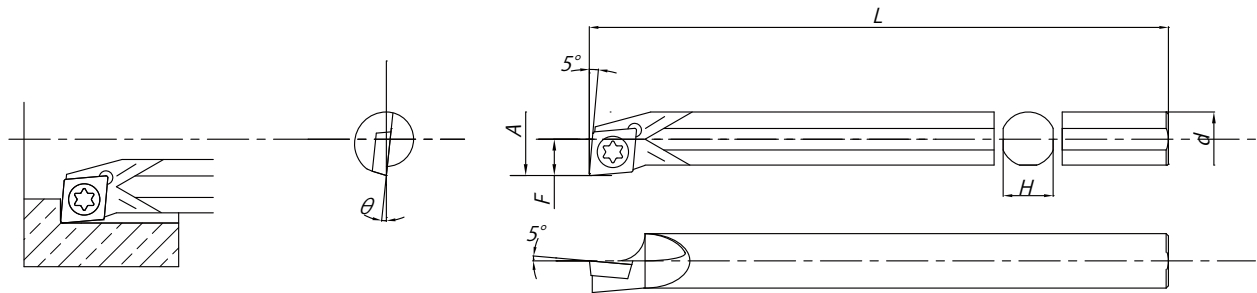

※) 本図は右勝手 (R) を示します。
Above figures shows right hand tools.

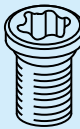
Cat. No. 型番	Stock 在庫		Min. Bore Dia. 最小 加工径	Dimensions(mm) 寸法 (mm)				θ	基準 コーナ Radius 0.4	Spare Part 部品 Screw クランプスクリュー 	Applicable Insert 使用チップ
	R	L		φA	φd	H	L				
C10-SCLP ㊦ 08-12V-175	●	●	12	10	9	175	6	8°	0.4	S-3STR	CP**0802**
SCLP ㊦ 08-12V-80	●	△				80					
SCLP ㊦ 08-12V-105	●	●				105					
C12-SCLP ㊦ 09-16V-175	●	●	16	12	11	175	8	5°		S-4065TR	CP**0903**
SCLP ㊦ 09-16V-90	●	△				90					
SCLP ㊦ 09-16V-120	●	●				120					
C16-SCLP ㊦ 09-20V-210	●	●	20	16	15	210	10	3°		S-4TR	
SCLP ㊦ 09-20V-110	●	△				110					
SCLP ㊦ 09-20V-145	●	△				145					
C20-SCLP ㊦ 09-25V-245	●	●	25	20	19	245	12.5	0°			
SCLP ㊦ 09-25V-125	△	△				125					
SCLP ㊦ 09-25V-165	△	△				165					

※) 右勝手 (R) ホルダには左勝手 (L) チップ、左勝手 (L) ホルダには右勝手 (R) チップが適合します。

※) Right handed toolholders are applicable with left handed or neutral inserts, Left handed toolholders are applicable with right handed or neutral inserts.

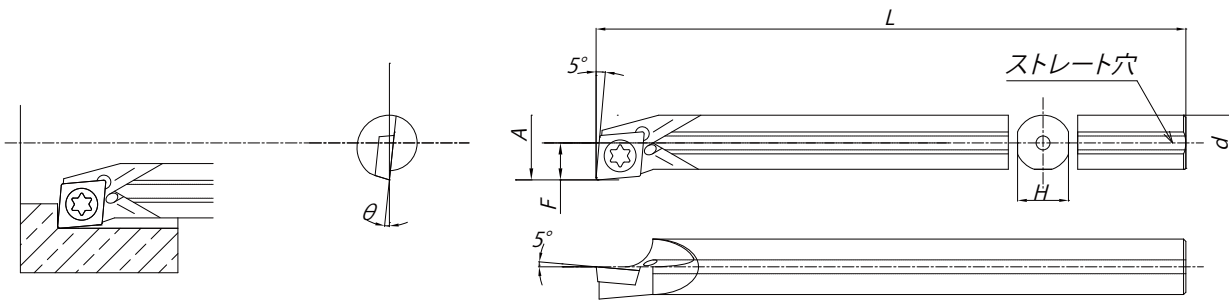

※) 本図は右勝手 (R) を示します。
Above figures shows right hand tools.

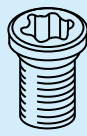
new Cat. No. 型番	Stock 在庫		Min. Bore Dia. 最小 加工径 ϕA	Dimensions(mm) 寸法 (mm)				θ	基準 コーナ Nose Radius R	Spare Part 部品	Applicable Insert 使用チップ				
	R	L		ϕd	H	L	F			Screw クランプスクリュー 					
E10-SCLP ㄥ 08-12V-175	●	●	12	10	9	175	6	8°	0.4	S-3STR	CP**0802**				
SCLP ㄥ 08-12V-80	●	△				80									
SCLP ㄥ 08-12V-105	●	●				105									
E12-SCLP ㄥ 09-16V-175	●	●	16	12	11	175	8	5°		0.4	S-4065TR	CP**0903**			
SCLP ㄥ 09-16V-90	●	△				90									
SCLP ㄥ 09-16V-120	●	●				120									
E16-SCLP ㄥ 09-20V-210	●	●	20	16	15	210	10	3°			0.4		S-4TR	CP**0903**	
SCLP ㄥ 09-20V-110	●	△				110									
SCLP ㄥ 09-20V-145	●	△				145									
E20-SCLP ㄥ 09-25V-245	●	●	25	20	19	245	12.5	0°					0.4		S-4TR
SCLP ㄥ 09-25V-125	△	△				125									
SCLP ㄥ 09-25V-165	△	△				165									

※) 右勝手 (R) ホルダには左勝手 (L) チップ、左勝手 (L) ホルダには右勝手 (R) チップが適合します。

※) Right handed toolholders are applicable with left handed or neutral inserts, Left handed toolholders are applicable with right handed or neutral inserts.

C-SWUBR/L

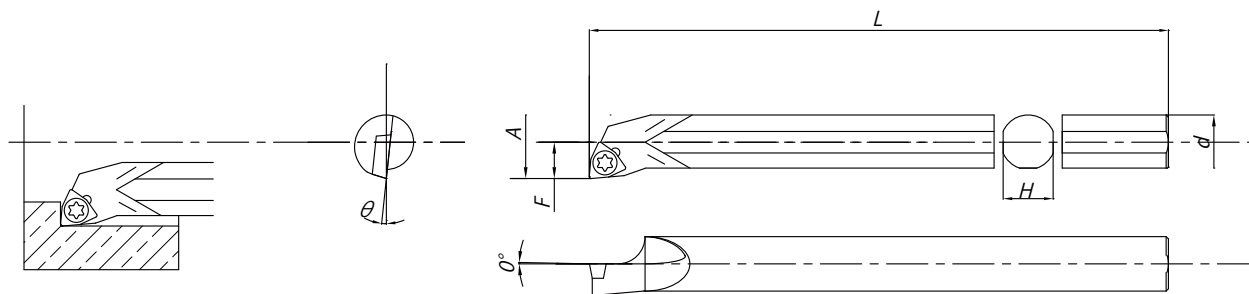

Above figures shows right hand tools.

※) 本図は右勝手 (R) を示します。

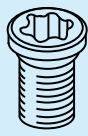
Cat. No. 型番	Stock 在庫		Min. Bore Dia. 最小 加工径	Dimensions(mm) 寸法 (mm)				θ	基準 コーナ Radius 0.2	Spare Part 部品	Applicable Insert 使用チップ
	R	L		φA	φd	H	L			F	
C05-SWUB 06-06V-100	●	●	6	5	4.4	100	3	15°	0.2		WB**0601**
C06-SWUB 06-07V-110	●	●	7	6	5.4	110	3.5	13°			
C07-SWUB 08-08V-125	●	●	8	7	6.4	125	4	15°			
C08-SWUB 08-10V-140	●	●	10	8	7.2	140	5	13°			

※) 右勝手 (R) ホルダには左勝手 (L) チップ、左勝手 (L) ホルダには右勝手 (R) チップが適合します。

※) Right handed toolholders are applicable with left handed or neutral inserts, Left handed toolholders are applicable with right handed or neutral inserts.

C/E-SDUCR/L

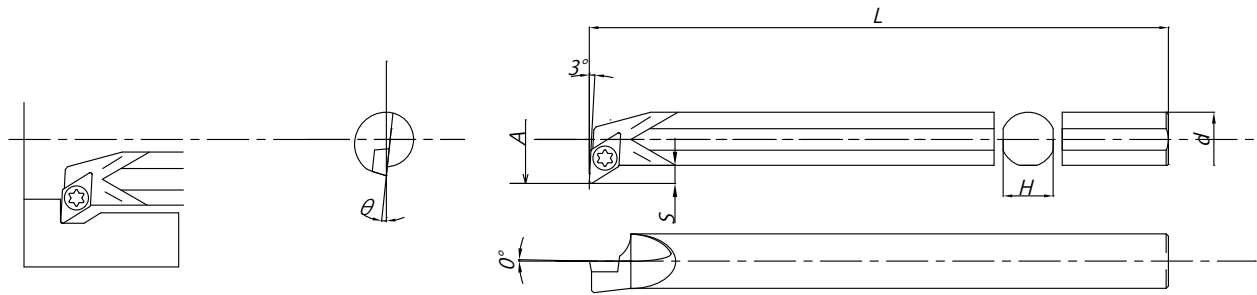

Above figures shows right hand tools.

※) 本図は右勝手 (R) を示します。

Cat. No. 型番	Stock 在庫		Min. Bore Dia. 最小 加工径	Dimensions(mm) 寸法 (mm)					θ	基準 コーナ Radius	Spare Part 部品	Applicable Insert 使用チップ
	R	L		φ A	φ d	H	L	F			S	
C10-SDUC ㄣ 07-14V-175	●	●	14	10	9	175	8.2	3.3	5°	0.4	S-2560TR	DC**0702**
C12-SDUC ㄣ 07-16V-175	●	●	16	12	11		9.2					
C12-SDUC ㄣ 11-20V-175	●	●	20				12.3					
C16-SDUC ㄣ 11-25V-210	●	●	25	16	15	210	14.3	6.1		0.8	S-4085TR	DC**11T3**
SDUC ㄣ 11-25V-145	●	●				145						
SDUC ㄣ 11-25V-175	●	●				175						
C20-SDUC ㄣ 11-32V-245	●	●	32	20	19	245	16.3					

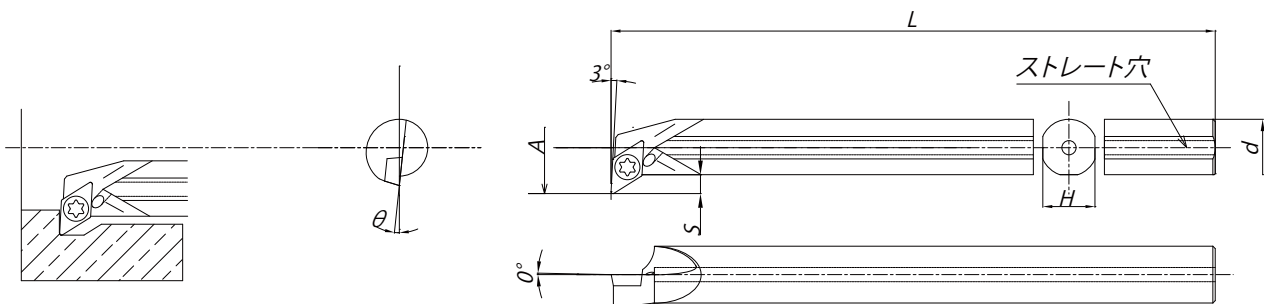

Above figures shows right hand tools.

※) 本図は右勝手 (R) を示します。



Cat. No. 型番	Stock 在庫		Min. Bore Dia. 最小 加工径	Dimensions(mm) 寸法 (mm)					θ	基準 コーナ Radius	Spare Part 部品	Applicable Insert 使用チップ
	R	L		φ A	φ d	H	L	F			S	
E10-SDUC ㄣ 07-14V-175	●	●	14	10	9	175	8.2	3.3	5°	0.4	S-2560TR	DC**0702**
E12-SDUC ㄣ 07-16V-175	●	●	16	12	11		9.2					
E12-SDUC ㄣ 11-20V-175	●	●	20				12.3					
E16-SDUC ㄣ 11-25V-210	●	●	25	16	15	210	14.3	6.1		0.8	S-4085TR	DC**11T3**
SDUC ㄣ 11-25V-145	●	●				145						
SDUC ㄣ 11-25V-175	●	●				175						
E20-SDUC ㄣ 11-32V-245	●	●	32	20	19	245	16.3					

※) 右勝手 (R) ホルダには左勝手 (L) チップ、左勝手 (L) ホルダには右勝手 (R) チップが適合します。

※) Right handed toolholders are applicable with left handed or neutral inserts, Left handed toolholders are applicable with right handed or neutral inserts.

C/E-SDQCR/L

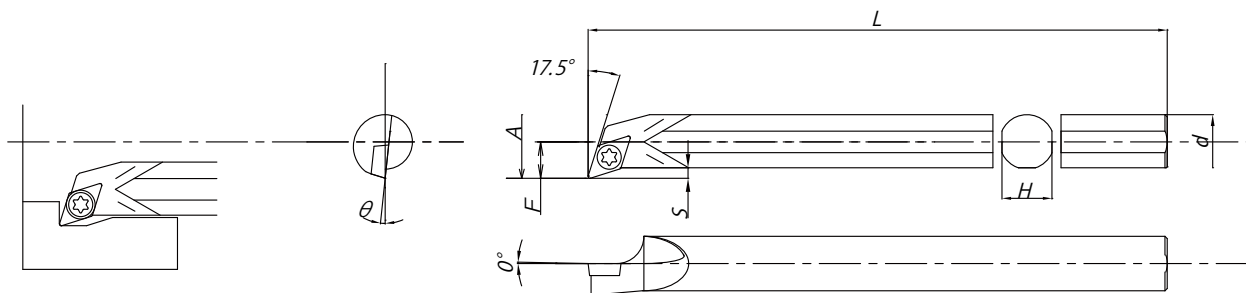

Above figures shows right hand tools.

※ 本図は右勝手 (R) を示します。

Cat. No. 型番	Stock 在庫		Min. Bore Dia. 最小加工径	Dimensions(mm) 寸法 (mm)					θ	基準 コーナ Radius	Spare Part 部品	Applicable Insert 使用チップ
	R	L		ϕA	ϕd	H	L	F			S	
C10-SDQC ㄥ 07-13V-175	●	●	13	10	9	175	7.5	2.1	10°	0.4	S-2560TR	DC**0702**
SDQC ㄥ 07-13V-105	●	△				105						
C12-SDQC ㄥ 07-16V-175	●	●	16	12	11	175	9.25	2.6	8°			
SDQC ㄥ 07-16V-120	●	△				120						
C16-SDQC ㄥ 07-20V-210	●	●	20	16	15	210	11.3	6°				
SDQC ㄥ 07-20V-145	●	△				145						
C20-SDQC ㄥ 11-25V-245	●	●	25	20	19	245	14.4	3.7	5°		S-4065TR	DC**11T3**
SDQC ㄥ 11-25V-175	△	△				175						
C25-SDQC ㄥ 11-30V-300	●	●	30	25	24	300	16.9	4°				
SDQC ㄥ 11-30V-200	△	△				200						

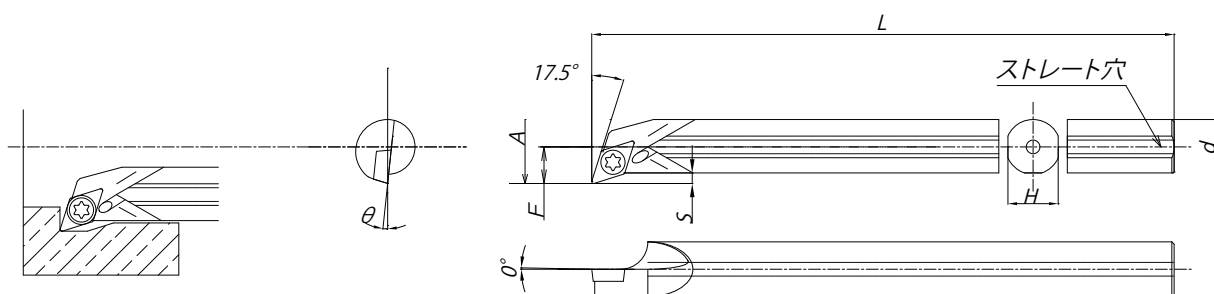

Above figures shows right hand tools.

※ 本図は右勝手 (R) を示します。



Cat. No. 型番	Stock 在庫		Min. Bore Dia. 最小加工径	Dimensions(mm) 寸法 (mm)					θ	基準 コーナ Radius	Spare Part 部品	Applicable Insert 使用チップ
	R	L		ϕA	ϕd	H	L	F			S	
E10-SDQC ㄥ 07-13V-175	●	●	13	10	9	175	7.5	2.1	10°	0.4	S-2560TR	DC**0702**
SDQC ㄥ 07-13V-105	●	△				105						
E12-SDQC ㄥ 07-16V-175	●	●	16	12	11	175	9.25	2.6	8°			
SDQC ㄥ 07-16V-120	●	△				120						
E16-SDQC ㄥ 07-20V-210	●	●	20	16	15	210	11.3	6°				
SDQC ㄥ 07-20V-145	●	△				145						
E20-SDQC ㄥ 11-25V-245	●	●	25	20	19	245	14.4	3.7	5°		S-4065TR	DC**11T3**
SDQC ㄥ 11-25V-175	△	△				175						
E25-SDQC ㄥ 11-30V-300	●	●	30	25	24	300	16.9	4°				
SDQC ㄥ 11-30V-200	△	△				200						

※ 右勝手 (R) ホルダには左勝手 (L) チップ、左勝手 (L) ホルダには右勝手 (R) チップが適合します。

※ Right handed toolholders are applicable with left handed or neutral inserts, Left handed toolholders are applicable with right handed or neutral inserts.

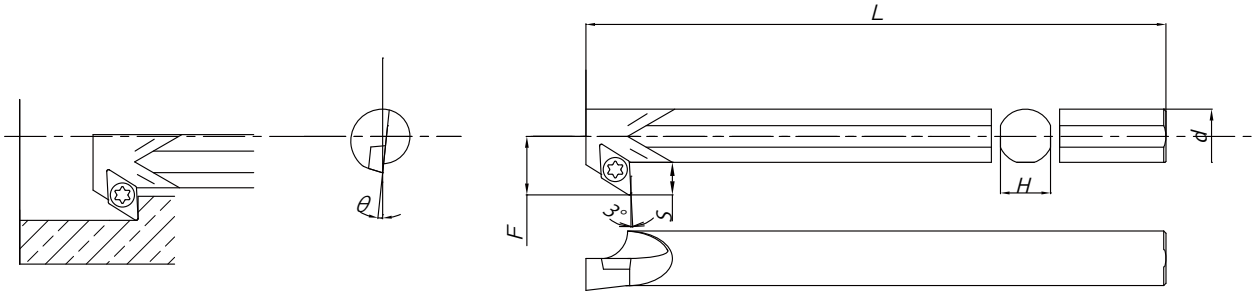

Above figures shows right hand tools.
※) 本図は右勝手 (R) を示します。

Cat. No. 型番	Stock 在庫		Min. Bore Dia. 最小加工径	Dimensions(mm) 寸法 (mm)						θ	基準 コーナ Radius	Spare Part 部品	Applicable Insert 使用チップ
	R	L		φA	φd	H	L	F	L5			S	
C10-SDZC $\frac{1}{2}$ 07-14V-175	●		14	10	9	175	8.3	9.5	3.3	5°	0.4	S-2560TR	DC**0702**
C12-SDZC $\frac{1}{2}$ 07-16V-175	●		16	12	11		9.3	10.5					
C16-SDZC $\frac{1}{2}$ 07-20V-175	●		20	16	15		11.3	15			6.1		
C16-SDZC $\frac{1}{2}$ 11-25V-180	●		25	16	15	180	14.1	15	6.1		0.8	S-4085TR	DC**11T3**
C20-SDZC $\frac{1}{2}$ 11-32V-180			32	20	19		16.1						

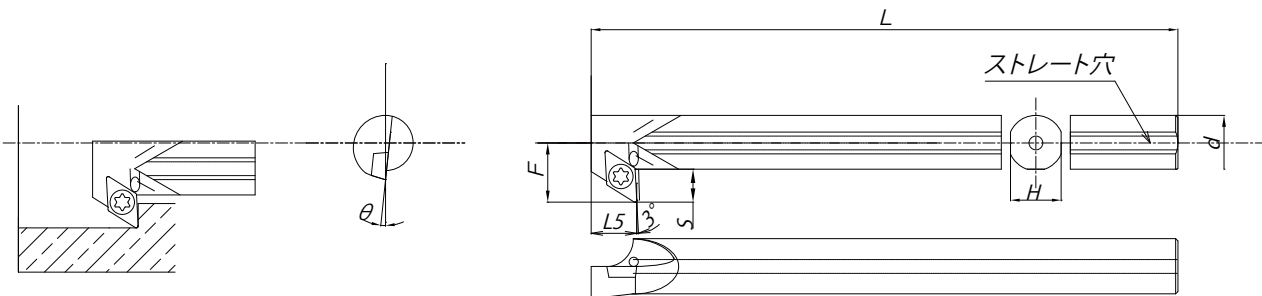

Above figures shows right hand tools.
※) 本図は右勝手 (R) を示します。



new Cat. No. 型番	Stock 在庫		Min. Bore Dia. 最小加工径	Dimensions(mm) 寸法 (mm)						θ	基準 コーナ Radius	Spare Part 部品	Applicable Insert 使用チップ
	R	L		φA	φd	H	L	F	L5			S	
E10-SDZC $\frac{1}{2}$ 07-14V-175	●		14	10	9	175	8.3	9.5	3.3	5°	0.4	S-2560TR	DC**0702**
E12-SDZC $\frac{1}{2}$ 07-16V-175	●		16	12	11		9.3	10.5					
E16-SDZC $\frac{1}{2}$ 07-20V-175	●		20	16	15		11.3	15			6.1		
E16-SDZC $\frac{1}{2}$ 11-25V-180	●		25	16	15	180	14.1	15	6.1		0.8	S-4085TR	DC**11T3**
E20-SDZC $\frac{1}{2}$ 11-32V-180			32	20	19		16.1						

C-SVQBR/L

SVQBR 型

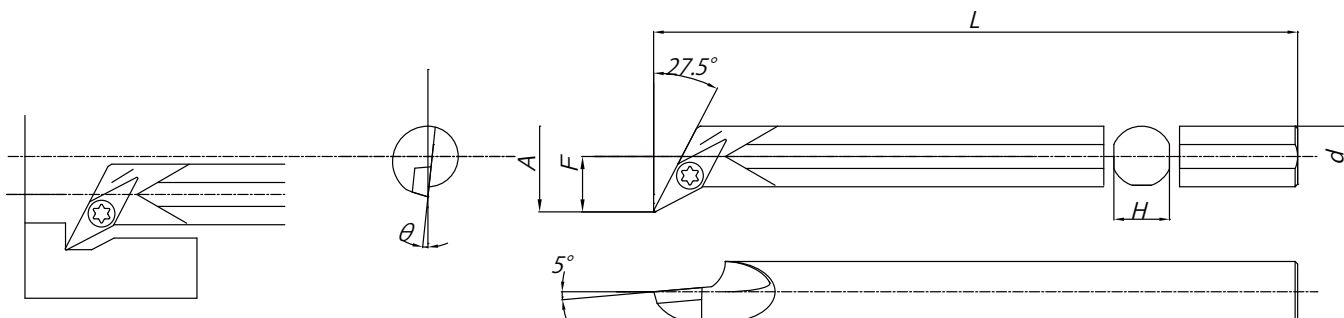

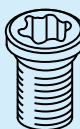
new Cat. No. 型番	Stock 在庫		Min. Bore Dia. 最小加工径	Dimensions(mm) 寸法(mm)					θ	基準コーナ Nose Radius R	Spare Part 部品 Screw クランプスクリュー 	Applicable Insert 使用チップ VB**1103**
	R	L		φ A	φ d	H	L	F				
C12-SVQB 1/2 11-18V-180	●		18	12	11	180	11	4.5	8°	0.4	S-2570TR	VB**1103**
C16-SVQB 1/2 11-22V-220	●		22	16	15	220	13.5	5				
C20-SVQB 1/2 11-26V-250			26	20	19	250	15.5					

C-SVJBR/L

SVJBR 型

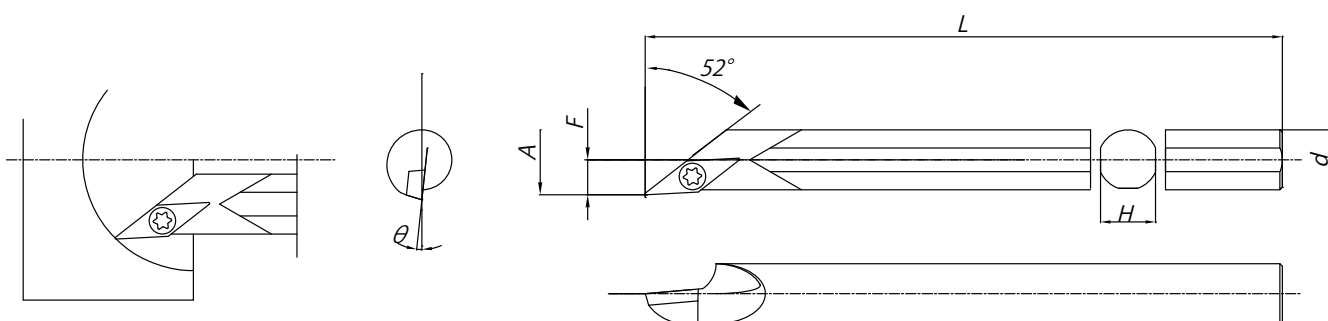

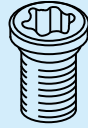
new Cat. No. 型番	Stock 在庫		Min. Bore Dia. 最小加工径	Dimensions(mm) 寸法(mm)					θ	基準コーナ Nose Radius R	Spare Part 部品 Screw クランプスクリュー 	Applicable Insert 使用チップ VB**1103**
	R	L		φ A	φ d	H	L	F				
C16-SVJB 1/2 11-20V-220	●		20	16	15	180	8	-	5°	0.4	S-2570TR	VB**1103**
C20-SVJB 1/2 11-25V-250	●		25	20	19	200	10					

※ 右勝手 (R) ホルダには左勝手 (L) チップ、左勝手 (L) ホルダには右勝手 (R) チップが適合します。

※ Right handed toolholders are applicable with left handed or neutral inserts, Left handed toolholders are applicable with right handed or neutral inserts.

The Voice of Great Masters

Stability for the Deep-hole-boring Manufacturing !

We used to use "K" company's carbide shank holders for making motorcycle parts by the overhang L/D=5. However, the depth boring results were unstable. After we changed the holder to tungsten holder, we achieved the most accuracy and stability. Now, we use only tungsten head holders. Furthermore a tungsten head holder life is 5 to 8 times longer than others we have used. Helping to reduce cost significantly.

Nissho-Giken Co., Ltd. IE Mr. Kine (Iwata, Shizuoka Jp.)

Focus on motorcycle parts we produce a wide amount of different parts. We have metal lather, machining, automatic lathe, etc... So we can do a variety of cutting manufacturing.



One and half year used

I'm so Surprised at a Stability Without Compromising the Quality of the Product.

We have use many others brand's throw-away holders. However, the surface finish was not consistent as the chip clamp worn down. When testing the tungsten head holder, I was so surprised that the chip clamp did not wear down and we could get stability without compromising the quality of the product. By improving chip discharge, we managed to increase productivity and overhang keeping the quality of the products. Although, it is still stage of testing, we are planning to adopt it for our other products.

"S" Co., Ltd. (Pseudonym) IE Mr. Saito (Nishio, Aichi)

We are good of precision cutting process, so we product various field of metal component.



It was dubious , now I'm a fan !

Preeminent Power for Hard Turning!

We use CBN along with carbide shank holders. For the holders, we have used several kinds of standard and special model. However, we were suffering with the surface finishing and grace (brightness). In order to get over this problem, we tested the special maxVpoint boring holder model. It exceeded all our expectation, removing our hard tuning troubles like precision of machined surface, hue, and micro chatter marks (waviness). Nowadays, we use the special maxVpoint boring holder, including all the newly introduced tungsten holder.

"T" Co., Ltd. (Pseudonym) IE Mr. D.K. (Hamamatsu, Shizuoka)

As a YAMAHA group associated company we undertake metallurgical, machining, grinding, cutting cogs, etc...



Special model of maxVpoint

Soneda Kogyo Co., Ltd.

1-12 Komaba, Iwata, Shizuoka,
438-0233, Japan

Tel. +81538-66-8605 Fax. +81538-66-8645

<http://www.soneda.jp>

町の巨匠の声

深穴ボーリング加工が安定！

従来K社の超硬ボーリングホルダーを使用し突き出し量L/D=5でオートバイ部品を、量産加工にて使用。加工深さが深い為、加工精度が今一つ不安定で有ったが、タングステンヘッドを使って突発性の不適合品が無くなり、安定加工を実現。現在当社で使用している超硬ボーリングホルダーは、特殊製作品も含め、全てタングステンヘッドに変更し、安定加工をしております。ホルダー寿命も長く(約5倍～8倍)、トータルで大幅なコストダウンになりました。

有限会社日昇技研 生産技術 木根様(静岡県磐田市)

オートバイ部品を中心に、多種少量の加工に対応。旋盤、マシニング、自動盤などを有し、多種多様な切削加工に対応しております。



使い始めて1年3ヵ月

製品品質が劣化せずに安定している事にビックリしています！

従来、各スローアウェイメーカーの物を使用していましたが、チップクランプ部の磨耗による寸法のバラつき、仕上がり面の劣化(安定性)に悩まされておりました。今回テスト的にタングステンヘッドを使用したところ、切屑によるチップクランプ部の磨耗も無く、何よりも製品品質が劣化せずに安定している事にビックリしています。突出し量を増やし、切屑の排出改善をしても、品質は変化無く維持されています。テスト継続中にも関わらず、他の製品にも使用したいと声が上がっています。

S株式会社(仮名) 生産技術 斉藤様(愛知県西尾市)

精密切削を得意とし各種分野の金属部品の製造をしております。



半信半疑が今ではファンに

ハードターニングに抜群の威力！

CBNによるボーリング加工を超硬ホルダーで行っておりました。標準、特殊型式と多数使用しておりましたが、加工面の精度と品位(輝き具合)で苦しんでおりました。タングステンヘッド超硬ボーリングホルダーを特殊で製作して試したところ、加工面精度、色合い、微小ビビリ(うねり)など、ハードターニングで苦しめられる問題が解消されました。現在では特殊超硬ホルダーも含め、新規導入はすべてタングステンヘッドになっております。

T株式会社(仮名) 生産技術 DK様(静岡県浜松市)

ヤマハ発動機の関連会社として金属加工旋盤、マシニング、研削、歯切りなどを多く手掛けております。



特殊製作品切りくず排出溝付き

〒438-0233

静岡県磐田市駒場1-12

有限会社曾根田工業

Tel. 0538-66-8605 Fax. 0538-66-8645

<http://www.soneda.jp>