

# PRODUCT NEWS

No.498

## 新製品

NEW PRODUCT

**NEW**

高硬度材加工用ソリッドボールエンドミル

**DIJET**

# ハード1ボール

刃長1Dスーパーショートタイプ/60HRC対応

"DH1 Coating" Solid carbide ball nose end mill suitable for Shrink fit and Hydro chuck

## Hard-One Ball SF5B形

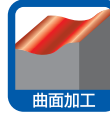

■  $\phi 1 \sim \phi 12$   
Size range: 1 -12 mm dia.

- 刃長1Dのスーパーショートタイプ。
- 焼きばめホルダやハイドロチャックで最適な突出し長さが得られ剛性・精度が向上。
- 60HRC高硬度材に対応し高能率・高精度加工が可能。

シームレス化により  
高精度加工を実現

**近日発売**  
COMING SOON

# ハード1ボール

"DH1 Coating" Solid carbide ball nose end mill suitable for Shrink fit and Hydro chuck  
Hard-One Ball

## SFSB形 SFSB type

- 高硬度材加工用（60HRC対応）
- 焼きばめ・ハイドロチャック対応
- 2枚刃、ねじれ角30°
- 刃長1D
- DH1コート
- For high hardened steel up to 60HRC.
- Suitable for shrink fit & hydro chuck
- 2 flutes / Helix angle 30°
- Effective cutting length: 1D
- DH1 Coating

■外径寸法許容差 Tolerance (mm)	
ボール半径 R of ball nose	R公差 Tolerance of R
R0.5~R6	±0.005

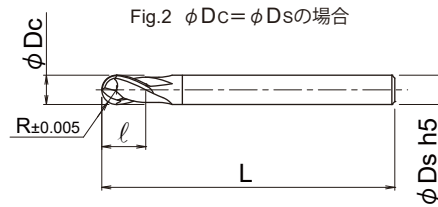
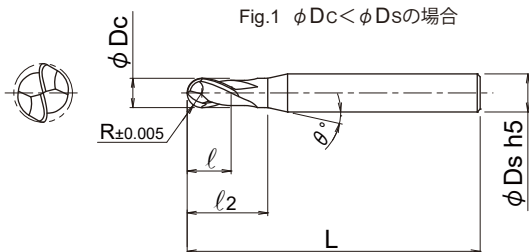

形番 Cat. No.	在庫 Stock	材種 Grade	寸法 (mm) Dimensions							Fig.
			R	$\phi Dc$	$l$	$l_2$	L	$\phi Ds$	$\theta^\circ$	
SFSB2010	◎		0.5	1	1	1.5	40	4	12°	1
SFSB2010-S6	◎		0.5	1	1	1.5	40	6	12°	1
SFSB2020	◎		1	2	2	2.5	40	4	10°	1
SFSB2020-S6	◎		1	2	2	2.5	40	6	10°	1
SFSB2030	◎		1.5	3	3	4	40	4	10°	1
SFSB2030-S6	◎		1.5	3	3	4	40	6	10°	1
SFSB2040	◎	DH110	2	4	4	5	40	4	—	2
SFSB2040-S6	◎		2	4	4	5	40	6	8°	1
SFSB2050	◎		2.5	5	5	6	50	6	5°	1
SFSB2060	◎		3	6	6	—	50	6	—	2
SFSB2080	◎		4	8	8	—	60	8	—	2
SFSB2100	◎		5	10	10	—	60	10	—	2
SFSB2120	◎		6	12	12	—	60	12	—	2

在庫表示 / Stock availability ◎ : 近日在庫品 / Soon to be stocked

## 切削性能 Cutting performance

被削材 Material : SKD11 (60HRC) 1.2379, D2  
 工具径 Tool dia. :  $\phi 3$   
 切削条件 Cutting conditions :  $Vc=170\text{m/min}$ ,  
 $n=18,000\text{min}^{-1}$ ,  $Vf=1,500\text{mm/min}$ ,  $f=0.083\text{mm/rev}$ ,  
 $ap=0.15\text{mm}$ ,  $ae=0.3\text{mm}$ , エアブロー Air blow,  
 焼きばめホルダ HSK-A63 タイプ使用

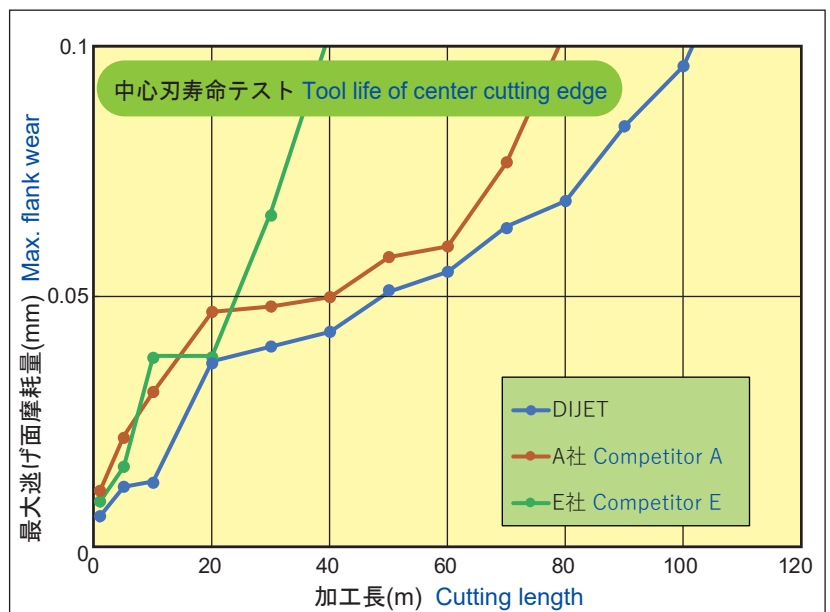
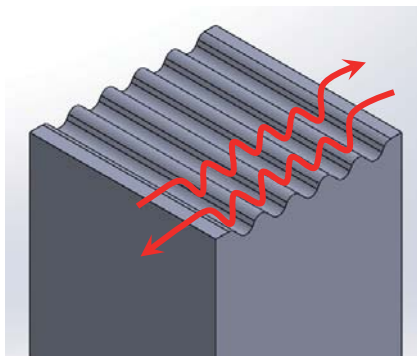

ハード1ボールはA社の約1.4倍、E社の約2.8倍長寿命を達成。  
 SFSB type improved tool life by 1.4 times compared with competitor A, and 2.8 times compared with competitor E.